

TM 11-5805-634-14

TECHNICAL MANUAL

**OPERATOR'S, ORGANIZATIONAL, DIRECT SUPPORT
AND GENERAL SUPPORT MAINTENANCE MANUAL**

AMPLIFIER-OSCILLATOR, TELEPHONE

TA-909(V)1/GTC

AND

AMPLIFIER-OSCILLATOR, TELEPHONE

TA-909(V)2/GTC

HEADQUARTERS, DEPARTMENT OF THE ARMY
AUGUST 1973

PROPRIETARY INFORMATION

Reproduction, dissemination or use of information contained herein for other than maintenance purposes is prohibited without prior written approval of SINGER/Tele-Signal.

CAUTION

The following precautions should be observed when operating units employing mercury-wetted polar relays:

1. When in normal operation, the relay must remain within $\pm 30^\circ$ of vertical and at no time must exceed $\pm 45^\circ$ with power applied.
2. If the relay has exceeded the vertical limits by lying horizontally, etc., it must be placed in a vertical position for 30 seconds prior to application of power. This gives the mercury time to settle; failure to do so will result in irreparable damage to the relay.

CHANGE }
No. 1 }

HEADQUARTERS
DEPARTMENT OF THE ARMY
WASHINGTON, DC, 2 August 1978

**Operator's, Organizational, Direct Support
and General Support Maintenance Manual
AMPLIFIER-OSCILLATOR, TELEPHONE
TA-909(V)1/GTC
(NSN 5805-00-093-5842)
AND
AMPLIFIER-OSCILLATOR, TELEPHONE
TA-909(V)2/GTC
(NSN 5805-00-093-5826)**

TM 11-5805-634-14, 10 August 1973, is changed as follows:

1. Title is changed as indicated above.
2. New or changed material is indicated by a vertical bar in the margin.
3. **Remove** and insert pages as indicated in the page list below.

<i>Remove</i>	<i>Insert</i>
i and ii	i and ii
1 and 2	1 and 2
63 through 68	63 through
4. **File this** change sheet in front of the publication for reference purposes.

By Order of the Secretary of the Army:

BERNARD W. ROGERS
General, United States Army
Chief of Staff

Official:

J. C. PENNINGTON
Brigadier *General United States Army*
The Adjutant general

DISTRIBUTION:

Active Army:

- USAINSCOM (2)
- DARCOM (1)
- OS Maj Comd (3)
- TECOM (2)
- USACC (5)
- USACC Sig Gp Okinawa (10)
- USACC Sig Gp Taiwan (10)
- USACC Sig Bde, Korea (2)
- 8th USA (3)
- I Corps (2)
- USAICS (3)
- USASIGS (5)
- Ft Monmouth (HISA)(33)USA Dep (2)
- USA Dep (2)

Depots (1) except

- SAAD (20)
- TOAD (14)
- LBAD (5)
- MAAG, Republic of China (2)
- USACSA (3)
- JUSMAG, Korea (1)
- USA Camp Carroll Dep (2)
- Units org under fol TOE:**
- 11-302 (1)
- 29-134 (1)
- 29-136 (1)
- 29-207 (2)
- 29-610 (2)

NG: None

USAR: None

For explanation of abbreviations used, see AR 310-50.

NOTE

This technical manual is an authentication of the manufacturer's commercial literature and does not conform with the format and content specified in AR 310-3, Military Publications. This manual does, however, contain available information that is essential to the operation and maintenance of the equipment.

TECHNICAL MANUAL }
No. 11-5805-634-14 }

HEADQUARTERS
DEPARTMENT OF THE ARMY
WASHINGTON DC, 10 August 1973

**OPERATOR'S, ORGANIZATIONAL, DIRECT SUPPORT, AND
GENERAL SUPPORT MAINTENANCE MANUAL FOR AMPLIFIER-
OSCILLATOR, TELEPHONE TA-909(V)1/GTC
NSN 5805-00-093-5842) AND AMPLIFIER-
OSCILLATOR, TELEPHONE TA-909(V)2/GTC
(NSN 5805-00-093-5826)**

CHAPTER A.	Introduction	Page 1
1.	Purpose and basic principles of models 2571D and E	3
2.	Purpose and basic principles of Oscillator Audio Frequency Model 70794	13
3.	Purpose and basic principles of the 2600-Hz keyer	27
4.	Purpose and basic principles of the model 26B Power Amplifier Module	37
5.	Purpose and basic principles of extender board model MC10064-08	57
APPENDIX A.	MAINTENANCE ALLOCATION ..	63

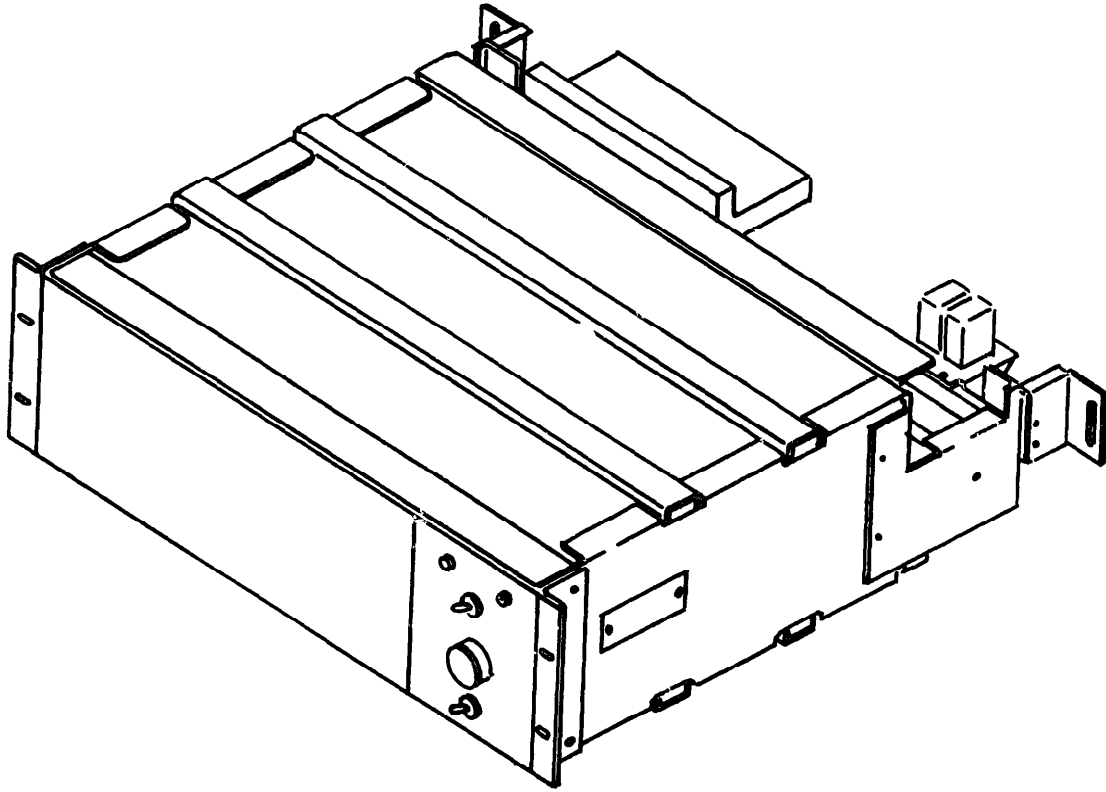

FIGURE 1. AMPLIFIER-OSCILLATOR TELEPHONE TA 909(V)/GTC.

Figure 1. Amplifier-Oscillator, Telephone TA-909(V)/GTC.

CHAPTER A INTRODUCTION

A.0 SCOPE

A.01 DESCRIPTION

This manual describes Amplifier-Oscillator, Telephone TA-909(V)1/GTC and Amplifier-Oscillator, Telephone TA-909(V)2/GTC hereinafter referred to as Singer-Telesignal Models 2571D and 2571E respectively. This manual covers the equipments installation, operation, and organizational direct and general support maintenance.

A.02 FORMS AND RECORDS

Reports of Maintenance and Unsatisfactory Equipment. Maintenance forms, records, and reports which are to be used by maintenance personnel at all maintenance levels are listed in and prescribed by TM 38-750.

Report of Packaging and Handling Deficiencies. Fill out and forward DD Form 6 (Packaging Improvement Report) as prescribed in AR 700-58/NAVSUPINST 4030.29/AFR 71-13MCO P4030.29A, and DLAR 4145.8.

Discrepancy in Shipment Report (DISREP) (SF 361). Fill out and forward Discrepancy in Shipment Report (DISREP) (SF 361) as prescribed in AR 56-38/NAVSUPINST 4610.33B/AFR 75-18/MCO P4610.19C and DLAR 4500.15.

A.03 REPORTING OF ERRORS

The reporting of errors, omissions, and recommendations for improving this publication by the individual user is encouraged. Reports should be submitted on DA Form 2028 (Recommended Changes to Publications and Blank Forms) and forwarded direct to Commander, US Army Communications and Electronics Materiel Readiness Command, ATTN: DRSEL-MA-Q, Fort Monmouth, New Jersey 07703.

A.04 REPORTING EQUIPMENT IMPROVEMENT RECOMMENDATIONS (EIR)

EIR's will be prepared using **DA Form 2407** (Maintenance Request.) Instructions for preparing EIR's are provided in TM 38-750, The Army Maintenance Management **System**. **EIR's should** be mailed direct to Commander, U.S. Army Communications and Electronics Materiel Readiness **Command, ATTN: DRSEL-MA-Q, Fort Monmouth, New Jersey 07703**. A reply will be sent direct to you.

A.05 DESTRUCTION OF ARMY ELECTRONICS MATERIEL

Destruction of Army electronics materiel to prevent enemy use shall be **in accordance with TM 750-244-2**.

A.08 DISCREPANCY IN SHIPMENT REPORT (DISREP) (SF361). Fill out and forward Discrepancy in Shipment Report (DISREP) (SF361) as prescribed in AR 55-38 (Army) NAVSUP PUB 459 (Navy)/AFM 75-34 (Air Force)/and MCO P4610.19 (Marine Corps).

A.09 REPORTING OF EQUIPMENT MANUAL IMPROVEMENTS. The reporting of errors, omissions, and recommendations for improving this publication by the individual user is encouraged. Reports should be submitted on DA Form 2028 (Recommended Changes to Publications) and forward direct to Commander, U.S. Army Electronics Command, ATTN: AMSEL-MA-C, Fort Monmouth, New Jersey 07703.

A.10 ADMINISTRATIVE STORAGE.

A.11 PROCEDURE. For procedure, forms and records, and inspection required during administrative storage of this equipment, refer to TM 740-90-1.

NOTE: This technical manual is an authentication of the manufacturer's commercial literature and does not conform with the format and content specified in AR 310-3, Military Publications. This manual does, however, contain available information that is essential to the operation and maintenance of the equipment.

CHAPTER 1

1.0 PURPOSE AND BASIC PRINCIPLES OF MODELS 2571D AND E

1.01 Application

1. The SINGER/Tele-Signal Model 2571D or E provides a source of 1600-Hz (D) or 2600-Hz (E) signaling to a number of external equipments. See figure 1

2. The primary application for the Model 2571D or E is to supply signaling tone for SINGER/Tele-Signal Model 60A in-band signaling modules.

1.02 Unit Description

The SINGER/Tel-Signal Model 2571D or E is designed to mount in a standard 19-inch cabinet and requires 5-1/4 inches of vertical space and a depth of 18 inches.

1.03 References

Chapter

- | | |
|---|---|
| 2 | Oscillator, Audio Frequency Model 70794 |
| 3 | Oscillator, Audio Frequency Model 70795 |
| 4 | Power Amplifier Module Model 26B |
| 5 | Extender Board Model MC10064-08 |

1.04 Functional Description (See figure 3)

1. The Model 2571D) or E Oscillator Amplifier consists essentially of two 70794 or 70795 Tone Keyers, two Model 26B Power Amplifier Modules and associated control circuits.

2. The Model 70794 or 70795 Tone Keyer provides the source of the 1600 Hz or 2600 Hz signaling. The keying input is connected to a constant -12 Vdc so it is always in the "ON" or "KEYED" mode producing a constant tone.

3. The output of each 70794 or 70795 Tone Keyer is connected to the input of a corresponding Model 26B, thus forming a redundant signaling source that provides the necessary power to drive not less than 240 single frequency signaling modules at a remote location. The output of the Model 26B passes through a transfer relay and then makes 12 appearances at a rear-mounted telephone-type terminal block that may be connected to the cabinets and shelves containing the Model 60A single frequency units.

4. During normal operation, one tone keyer/power amplifier circuit is considered the primary and the other the secondary, as determined by a front panel PRIMARY OSCILLATOR SELECT switch. Each power amplifier output is monitored by a tone level monitor on the Model 26B. If the primary circuit drops below a predetermined level, an alarm will cause automatic switching to the secondary source. This switching also produces a local alarm indication by a lamp mounted on the front panel of the unit. It also produces a remote indication (by relay form C contacts) via terminals located on the

rear terminal block marked MN (minor alarm). These may be extended to any remote location desired. If both outputs fail, a major alarm (MJ) is furnished. An audible indication is given if either alarm condition exists. Alarm lamps and an audible ALARM DISABLE switch are mounted on the front panel of the unit.

5. The Model 26B Power Amplifier Module provides another function besides amplification of the tone. The entire terminal is powered from -48 Vdc. The Models 26B, 70794 and/or 70795, require ± 12 Vdc and the 70794 requires +3.6 Vdc. The Model 26B converts the -48 Vdc to provide the proper logic voltage as necessary.

2.0 SPECIFICATIONS OF MODELS 2571D) AND 2571E

2.01 General Characteristics

Function: Signal supply terminal provides a source of 1600 Hz or 2600 Hz signaling to not less than 240 external equipments.

Output Capacity: 12 outputs to drive 240 60A tone input circuits.

Output Frequency: 1600 Hz or 2600 Hz

Power Requirements : -48 Vdc (±10%) @ 1 amp (nominal)

Dimensions: 5-1/4" high x 19-1/4" wide x 18" deep

2.02 List of Major Components

<u>Part Number</u>	<u>FSCM</u>	<u>Description</u>	<u>Quantity</u>
70796	10241	Equipment Shelf	1
PJ104	70674	Terminal Block	1
70794, 70795	10241	Modified Tone Keyer	2
26B	10241	Power Amplifier	2
MC10004-08	10241	Extender Board	1

NOTE

FSCM- Federal Supply Code to Manufacturer

3.0 INSTALLATION INSTRUCTIONS: FOR MODELS 2571D AND 2571E

3.01 Mechanical Arrangement

1. The Model 2571D or E is designed to mount in a standard 19-inch cabinet and requires 5-1/4 inches of vertical space and a depth of approximately 18 inches.

2. All modules contained within the terminal are of the plug-in type which can easily be removed for maintenance.

3. All external signal and power connections are made on a telephone-type terminal block located at the rear of the assembly. External connections are made on the top of the block.

4. The alarm and transfer relays are plug-in and are mounted on a bracket in the rear of the unit.

4.0 OPERATING INSTRUCTIONS FOR MODELS 2571D AND 2571E

4.01 General

The following controls are located on the front panel of the Amplifier-Oscillator Group 2571D-2571E. See figure 2.

<u>Control</u>	<u>Nomenclature</u>	<u>Function</u>
DS1	OSC 1	Red light illuminates when oscillator #1 fails.
DS2	OSC 2	Red light illuminates when oscillator #2 fails.
S1	PRIMARY OSCILLATOR SELECT	Selects desired oscillator for operation
Sonalert DS3	Audible Alarm	Sounds when a malfunction occurs in either power amplifier.
S2	AUDIBLE ALARM-ACTIVE/DISABLE	Manual control to control audible alarm

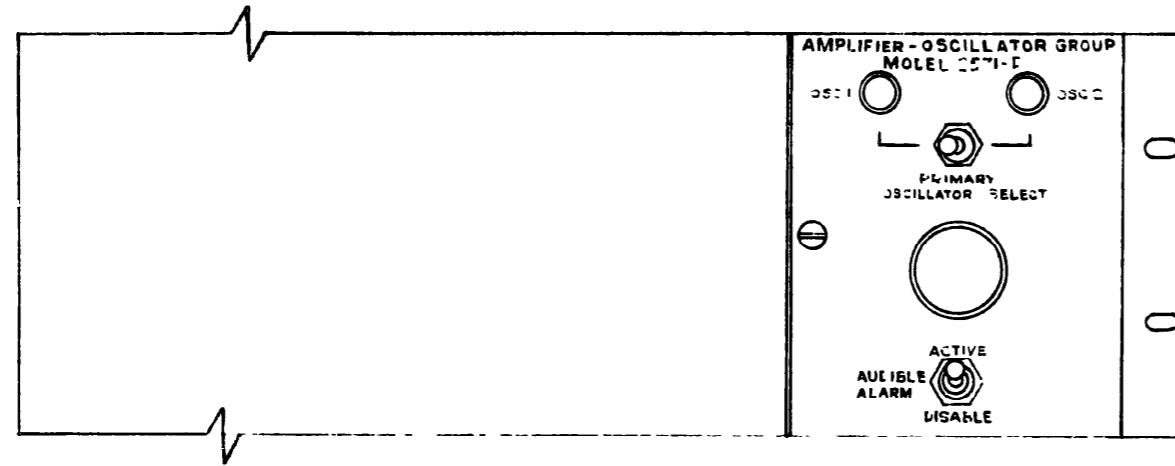

Amplifier Oscillator 2571D

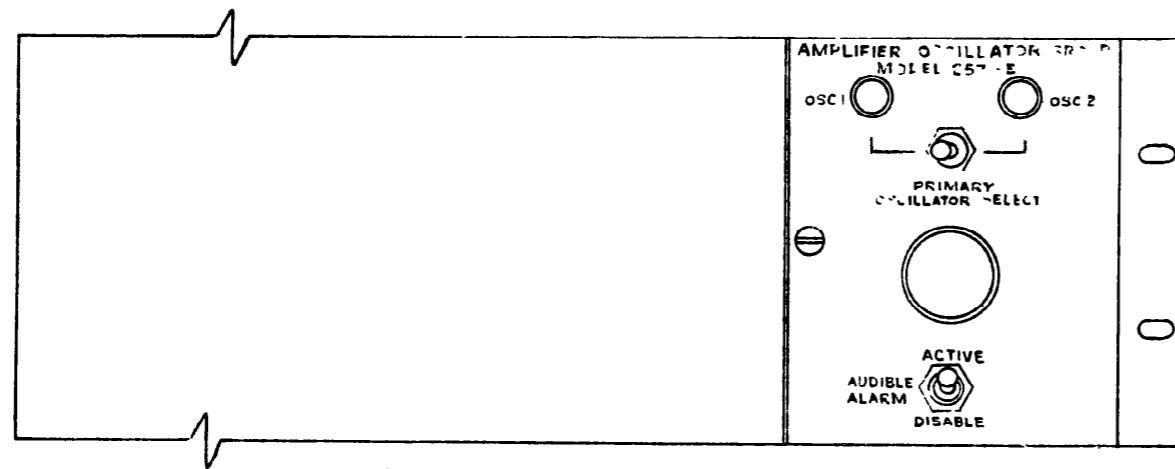

Amplifier Oscillator 2571E

Figure 2. Controls and Indicators

5.0 THEORY OF MODELS 2571D AND 2571E

5.01 Circuit Description (See figure 3)

1. Each 70794 or 70795 Tone Keyer is connected to a corresponding Model 26B Power Amplifier Module, thus forming a redundant signaling source.

2. The PRIMARY OSCILLATOR SELECT switch S1 on the front panel of the Model 2571D or E Oscillator Amplifier determines which tone keyer/power amplifier circuit will normally provide the output. Setting the switch to the OSC 1 position, for example, selects the tone Keyer/power amplifier modules respectively located in shelf locations J1 and J3. The output signal, appearing at pin 19 of the selected power amplifier is then applied through normally closed contacts 6 and 7 of relay E1 and the position/contacts of S1 to the 12 signaling outputs via resistors R1 through R12.

3. If a malfunction occurs in the selected power amplifier, an alarm relay in the power amplifier deenergizes. This routes a ground signal to OSC 1 indicator lamp DS1 on the front panel of the oscillator amplifier, lighting the red lamp. The same alarm relay removes a ground signal from the winding of relay K1 in the oscillator amplifier, causing it to deenergize. When relay K1 deenergizes, several events occur simultaneously:

- a. contacts 5 and 7 of relay E1 make, thus routing the output from pin 19 of the second power amplifier to S1 and the output terminals of the rear of the shelf.

- b. contacts 8 and 9 of relay K1 provide ground to the Sonalert alarm on the front panel of the Oscillator Amplifier, causing it to sound.
- C. contacts 11 and 12 of relay K1 close, thus producing a minor alarm signal (MN) at a rear terminal of the oscillator amplifier for external monitoring purposes.

4. When relay K1 deenergizes, the selected power amplifier output is disconnected from the 12 signaling outputs and is replaced by the redundant amplifier output.

5. If the PRIMARY OSCILLATOR SELECT switch is set to the OSC 2 position, the second tone keyer/power amplifier circuit is selected. The operation of this circuit is identical to the circuit just described, except that OSC 2 indicator lamp DS2 lights to indicate a malfunction in the second power amplifier, and relay K2 performs the switching function.

6. If both power amplifiers fail simultaneously, both relays K1 and K2 deenergize and route a major alarm signal MJ to an output terminal for external monitoring purposes. This signal is in the form of a ground that is routed in series through deenergized contacts 14 and 15 of both relays K1 and K2 to the output terminal. A complement signal MJ is also provided which produces an open circuit when both relays are de-energized.

7. The alarm contact circuit is floating with respect to the equipment ground, an alarm common (AC) is provided on the rear terminal block for USC with both MN and NJ external alarms.

6.0 MAINTENANCE INSTRUCTIONS FOR MODELS 2571D AND 2571E

6.01 General

1. SINGER/Tele-Signal equipment is designed and tested under sophisticated reliability/maintainability-oriented engineering and quality assurance programs to insure maximum operational life and minimum maintenance.

2. A periodic preventive maintenance procedure would enhance the long term operation of the equipment. However, the equipment should require only occasional minor adjustments as component aging occurs.

3. Expeditious inspection and servicing, if required, will be facilitated by easily accessible, labeled monitor facilities, inter-changeable plug-in modules, and standard replacement parts.

4. Instruction manuals are appended to this narrative which provide complete schematics and descriptions to assist maintenance procedures.

6.02 System Alignment

1. Connect level meter between TP3 and TP4 (ground) on the Model 26B Power Amplifier (in card cage location J3). Adjust the level control (R18) of the keyer in location J1 for 0.5 rms. Re-connect level meter between TP5 and TP4. Adjust amplifier output (R34) to 0.85 V rms. Adjust alarm input level (R9) so unit alarm light just indicates, then reset amplifier output (R34) to 1V rms.

2. Repeat procedure outlined in paragraph 0.02-1 for the second channel. (Keyer in location J2, Power Amplifier in location J5.)

CHAPTER 2

7.0 PURPOSE AND BASIC PRINCIPLES OF OSCILLATOR, AUDIO FREQUENCY
MODEL 70794**7.01** Application

The Oscillator, Audio Frequency Model 70794, hereinafter referred to as the 1600-Hz Keyer is used in the signaling tone supply Model 2571D to provide a constant 1600-Hz signal for use in peripheral equipment. The frequency is crystal-controlled at 409.6 kHz and divided by **256** to obtain the required audio frequency. The tone is constantly applied as long as the circuit is energized.

7.02 Unit Description

The 1600-Hz Keyer is mounted on a printed circuit board. This circuit board is inserted into Model 605S equipment shelf, and is a part of the signaling tone supply Model 2571D.

8.0 SPECIFICATIONS FOR OSCILLATOR, AUDIO FREQUENCY MODEL 70794

8.01 Band-Pass Filter

Output Frequency : 1600 Hz
Distortion: Less than -50 dB
Output Level: 0.5 Vrms, adjustable
Output Impedance: 600 ohms, nominal

8.02 Operating

Operating Controls: None
Maintenance Controls: Level Control (R18)
Monitoring Facilities: Test Points - TP11, TP10, 1600 Hz

8.03 Environmental

Operating Temperature: 0° to +55°C
Storage Temperature: -55° to +60°C
Altitude: 40,000 feet

8.04 Physical

Size: 4-5/8" high x 11" long x 1" wide
Weight: 1 lb., approximately

9.0 INSTALLATION INSTRUCTIONS FOR OSCILLATOR, AUDIO FREQUENCY MODEL 70794.

9.01 General

The 1600-Hz keyer is designed to mount in a Model 605S equipment shelf. To install the module, slide it into the appropriate equipment position in the shelf until the fingers of the card mate with the 44-pin connector mounted on the rear of the shelf. An ejector lever in front of the module facilitates removal from the shelf.

9.02 External Power Connections

External power enters the card on the following pins:

+12 Vdc - Pin 10

-12 Vdc - Pin 11 - 14

+3.9 Vdc - Pin 8

Common - Pin 20

9.03 Output Signal Connections

The aggregate line output signal appears on the card as pin 1.

(Located in back of manual.)

Figure 3

(Located in back of manual.)

10.0 OPERATING INSTRUCTIONS FOR OSCILLATOR, AUDIO FREQUENCY MODEL 70794

10.01 Strapping

1. Determine that shorting plugs are between TP1 and TP2 and between TP4 and TP5 (Refer to Figure 5, Keyer 70794).

2. Refer to Figure 6, Keyer 70794, and determine that six straps are in place at the A, C, E, H, J and L locations.

11.0 THEORY

11.01 General

1. Refer to Figure 5, schematic diagram for Keyer 70794.

2. The 409.6-kHz fundamental frequency crystal oscillator signal is amplified and inverted in transistors Q1 and Q2 and passed through OR gates NG1. The signal from pin 3 of OR gate NG1 is the timing or clock signal which is applied to the dividing flip-flops FF1 through FF4 inclusive, in successive steps for a total division of 256 to produce a constant carrier frequency of 1600 Hz.

3. The output of the dividing flip-flops is strapped to OR gates NG2, inverted and amplified in Q5 and Q6 emitter follower. This signal is strapped to the input of an output filter consisting of inductors L101, L102, L103 and capacitors C101 through C107 inclusive. The output of the filter is available at TP2.

4. The carrier output of the filter appears at pin 4 with a 0.5 *Vrms* level and a frequency of 1600 **HZ**. Harmonic distortion does not exceed -50 dB.

12.0 MAINTENANCE

12.01 Equipment Required

1. Frequency Meter
2. Distortion Analyzer
3. VTVM

12.02 Testing

1. Apply +12 Vdc to pin 10, -12 Vdc to pin 11 and +3.6 Vdc to pin 8. (These voltages are available on the 26B power amplifier.)
2. Connect frequency meter distortion analyzer and VTVM between TP1, TP2, TP4 or TP5 and ground.
3. Adjust R18 for 0.5 Vrms, and observe frequency of 1600 (\pm 1) Hz. Distortion should not exceed -50 dB.

(Located in back of manual.)

Figure 5. Keyer 70794, Schematic

(Located in back of manual.)

Figure 6. Keyer 70794, Assembly

CHAPTER 3

13.0 PURPOSE AND BASIC PRINCIPLES OF THE 2600-HZ KEYER

13.01 Application

The 2600-Hz Keyer is used in the signaling tone supply Model 2571E to provide a constant 2600-Hz signal for use in peripheral equipment,

13.02 Description

The Oscillator, Audio Frequency Model 70795 hereinafter referred to as 2600-Hz Keyer, is mounted on a printed circuit board. This circuit board is inserted into Model 605S equipment shelf and is a part of the signaling tone supply Model 2671E. The frequency is crystal controlled to 332.8 kHz and divided by 128 to obtain the required audio frequency. The tone is constantly applied as long as the circuit is energized.

14.0 SPECIFICATIONS OF THE 260-HZ KEYER

14.01 Band Pass Filter

Output Frequency: 2600 Hz
 Distortion: Less than -50 dB
 Output Level: 0.5 Vrms, adjustable
 Output Impedance: 600 ohms, nominal

14.02 Operating

Operating Controls: None
 Maintenance Controls: Level Control (R18)
 Monitoring Facilities: Test Points - TP11, TP10 2600 Hz

14.03 Environmental

Operating Temperature: 0° to +55°C
 Storage Temperature: -55° to +60°C
 Altitude: 40,000 feet

14.04 Physical

Size 4-5/8" high x 11" long x 1" wide
 Weight: 1 lb., approximately

15.0 INSTALLATION INSTRUCTIONS FOR THE 2600-HZ KEYER

15.01 General

The 2600-Hz Keyer is designed to mount in a Model 605S equipment shelf. To install the module, slide it into the appropriate equipment position in the shelf until the fingers of the card mate with the 44-pin connector mounted on the rear of the shelf. An ejector lever in front of the module facilitates removal from the shelf.

15.02 External Power Connections

External power enters the card on the following pins:

+12 Vdc - Pin 10

-12 Vdc - Pin 11 - 14

+3.9 Vdc - Pin 8

Common - Pin 20

15.03 Output Signal Connections

The aggregate line output signal appears on pin 1 of the card.

16.0 OPERATING INSTRUCTIONS FOR THE 2600-HZ KEYER

16.01 Strapping

1. Determine that shorting plugs are between TP1 and TP2 and between TP4 and TP5 (Refer to Figure 7, Keyer 70795).

2. Refer to Figure 8, Keyer 70795, and determine that six straps are in place at the B, C, E, H, J, and L locations.

17.0 THEORY

17.01 General

1. Refer to Figure 7 schematic diagram for keyer 70795.

2. The 332.8-kHz fundamental frequency crystal oscillator signal is amplified and inverted in transistors Q1 and Q2 and passed through OR gates NG1. The signal from pin 3 of OR gate NG1-1 is the timing or clock signal which is applied to the dividing flip-flops FF1 through FF4 inclusive, in successive steps for a total division of 128 to produce a constant carrier frequency of 2600-Hz.

3. The output of the dividing flip-flop is strapped to OR gates NG2, inverted and amplified in Q5 and Q6, emitter follower. This signal is strapped to the input of an output filter consisting of inductors L101, L102, L103 and capacitors C101 through C107 inclusive. The output of the filter is available at TP2.

4. The carrier output of the filter appears at pin 4 with a 0.5 Vrms level and a frequency of 1600 Hz. Harmonic distortion does not exceed -50 dB.

18.0 MAINTENANCE

18.01 Equipment required

1. Frequency Meter
- 2, Distortion Analyzer
- 3, VTVM

18.02 Testing

1. Apply +12 Vdc to pin 10, -12 Vdc to pin 11 and +3.6 Vdc to pin 8. (These voltages are available on the 26B power amplifier).
2. Connect frequency meter distortion analyzer and VTVW between TP1, TP2, TP4 or TP5 and ground.
3. Adjust R18 for 0.5 Vrms, and observe frequency of 2600 (± 1) Hz. Distortion should not exceed -50 dB.

(Located in back of manual.)

Figure 7. Keyer 70795, Schematic

(Located in back of manual.)

Figure 8. Keyer 70795, Assembly

CHAPTER 4

19.0 PURPOSE AND BASIC PRINCIPLES OF THE MODEL 26B POWER AMPLIFIER MODULE**19.01** Application

1. The Model 26B Power Amplifier Module is intended for use as a power amplifier, dc-to-dc converter, and a level sensing unit.
2. The power amplifier section is a general purpose audio facility capable of driving a loudspeaker load.
3. The dc-to-dc converter section is capable of accepting and converting a 48 Vdc line to plus 12V, minus 12V and plus 3.6 volts. These voltages are used to power the Model 26B internal circuitry and are fed out for external use. The Model 26B can also be powered from an external $\pm 12V$ and common.
4. The level sensing circuits "sensing" level is adjustable. The circuit is used to determine when the input level rises above or falls below a predetermined, preset level and activates an "alarm".

19.02 Unit Description

1. The Model 26B Power Amplifier module consists of a power amplifier circuit, a dc-to-dc converter circuit and a level sensing circuit.
2. The unit is designed to be compatible with tone and alarm equipment such as SINGER/Tele-Signal Model 47A AM Tone Keyer and Model 62BA Tone Monitor, but it also has the capability of operating in other configurations.

3. The unit consists of a plug-in card which is compatible with our standard 605S shelf.

19.03 Mechanical Description

1. The Model 26B module is a plug-in card approximately 11 inches long, 4-1/2 inches high and 3/4 inches wide which fits into a SINGER/Tele-Signal 605S-type shelf.

2. The unit is of solid-state design, taking advantage of the latest in integrated circuit and transistor techniques. All external connections to the module are made via the connector on the shelf.

20.0 SPECIFICATIONS OF THE MODEL 26B POWER AMPLIFIER MODULE

20.01 Electrical Characteristics

1. DC-to-DC Converter -

<u>Input</u>	<u>output</u>	<u>Max. Output Current</u>
48 Vdc at 500 mA	+12 (± 1.5)V	100 mA
	-12 (± 1.5)V	100 mA
	+3.6V	50 mA
	Using the above plus and minus 12V as 24V	150 mA
	+12, -12, Common at 500 mA	+3.6V

2. Amplifier -

Input Impedance:	SK nominal, amp + sensing composite
Freq. Response:	200 - 4000 Hz ± 1 dB
Power Output:	1.5 watts into 10-ohm steady tone sine wave
Voltage Output:	20 20 VPP into 56-ohms or higher load.
Approx. Sensitivity:	0.06 Vrms with 600-ohm load
(For full output with output control set for max. gain.)	0.028 Vrms with 10-ohm load

3. Level Sensing-

Input Impedance: Nominal SK, amp + sensing composite

Operating Input Range: -30 dBm to +10 dBm (low range can be extended if the reference voltage is lowered with R19)

Time Delay: Varies with the difference between the operating level and desired alarm activation, nominally 1 second.

output: Relay contacts -1 form C.

20.02 Physical Characteristics

Size: 11" x 4-1/2" x 3/4"

Weight: 12 oz. (approx)

Construction: Plug-in printed circuit card.

Operating Temperature Range : 0° to 55°C

Storage Temperature Range : -30° to 65°C,

Relative Humidity Tolerance: 0 to 95%

Altitude: Up to 10,000 ft above sea level operating.
Up to 50,000 ft above sea level non-operating

20.03 Controls

Operating: output

Factory Adjustment: Reference
Input
+3.6V adjust (R5)

20.04 Test Points

TP1:	Level Detect Relay Input
TP2:	Reference Voltage
TP3:	Tone Input
TP4:	System Common
TP5:	Amplifier Output

21.0 INSTALLATION INSTRUCTIONS

21.01 Mechanical Arrangement

1. The nodule is mechanically designed to be inserted into a standard 605S enclosure, or equivalent, shelf.

2. All connections to the module are made via **the module's** connector at the rear of the shelf.

21.02 Power Connections and Modes of Operation

1. For 48V operation, the external 48V (@0.5A minimum) is brought into the module through connector pins 16 (minus) and 14 (plus) In this mode, voltages can be fed out of the Model 26B for external use as follows:

- a. +12V (at 100 mA maximum) pin 11.
- b. -12V (at 100 mA maximum) pin 10 (and/or pin 7 if used with another 26B in the fall-back mode).
- c. +3.6V (at 50 mA maximum) pin 22.

These are used in conjunction with the 26B Common, pins 20 and 21.

2. If ± 12 volts and a common from an external source are available, the +12V is fed in at pin 11, the -12V in at pin 10, and the common at pins 20 or 21. Plus 3.6V will still be available from the 26B at pin 22. The plus and minus inputs in this mode should be capable of 500 mA minimum each.

CAUTION

Strict attention must be paid to proper connection of commons when connecting other units and test equipment to the 26B in the 48V mode.

In this mode, system power common and 26B common (pins 20 and 21) are different lines and cannot be tied together.

Strapping for the above modes is presented in the following section.

21.03 Strapping

1. 48V Input Mode (Normal
Factory Strapping): Make straps A, B, C, E and H

2. +12, -12, Common
Input Mode : Make straps D and C. Break A, B,
E, C and H

3. To disable the amplifier in 48V mode, break straps E and C and make strap F. To disable the amplifier in the + and -12V mode, make strap F.

4. To monitor at input, make strap K. To monitor at output, make strap J (normal factory strapping).

NOTE

Pins 14 and 13 of P1 (rear connector) can be tied together in this mode so that TP4 can be used as a common if adjustment of the unit is necessary in this mode.

21.04 Factory-Adjustments

1. R5 is set for +3.6 Vdc (with reference to 26B common).
2. R19 reference set for -1 Vdc (with reference to 26B common).
3. High-level detector circuit set to activate when signal falls to 0.85 Vrms.

22.0 OPERATING INSTRUCTIONS FOR THE MODEL 26B POWER AMPLIFIER
MODULE

22.01 Level Sensing (Detector) Adjustment

1. Note that normally the input control is factory-adjusted so the circuit will activate if the signal falls to 0.85 Vrms*

2. If operation at a different level is desired, the following is the procedure recommended:

- a. Set the input control fully CCW.
- b. Connect AC VTVM between TP5 and TP4 (common).
- c. Set input level for the voltage level that is desired to activate the level detector circuit.
- d. Connect VOM between TP1 and 26B common. VOM will read -12 Vdc ($\pm 1.5V$).
- e. Very slowly turn Input Control CW until VOM indicates +9 (± 1)V.
- f. Increase input to desired operating level. VOM should stay at +9V, lower level slowly.
- g. Repeat step c. The circuit should switch to -12V at the preset level.

NOTE

It may be necessary to touch up the input control after initial adjustment, by varying the input control and checking at the desired levels until the degree of accuracy desired is obtained,

22.02 Amplifier Adjustment

A signal input of approximately 0,028 Vrms will drive the amplifier to full output with a 10-ohm load, and an input of approximately 0.06 Vrms will drive it to full output with a 600-ohm load (with the output control, R34, set for minimum attenuation). With higher inputs,, the amplifier output can be set for any desired level via R34.

23.0 THEORY OF MODEL 26B AMPLIFIER MODULE

23.01 DC-to-DC Converter

(fig. 9)

1. The 48 Vdc is fed into the 26B at pin 16 (minus) and pin 14 (plus). R2, C1 and C2, R1, C3 comprise a filter designed to keep transients that might occur on the 48V line from affecting the operation of zeners VR1 and VR2. VR1 and VR2 are 12-volt zener diodes. R1, R2, VR1 and VR2 comprise a series circuit shunting the 48V incoming dc. Utilizing the point where VR1 and VR2 are tied together as a reference (common), the circuit now supplies plus and minus 12 Vdc for the 26B internal circuitry and external use. Plus 12V is fed out at pin 11, minus 12V at pin 10, 26B common at pins 20 and 21. A -12 volts for fall-back operation using two 26B cards is fed out at pin 7. If 24V output is required, the 26B common is not used. A series regulator circuit consisting of Q1 and Q2 is connected across VR2 and provides regulated +3.6V for external use. This voltage is adjustable by means of R5.

2. R22, C13 and C14, R23, C15 comprise a filter designed to keep transients that might occur on the 48V battery from affecting VR3 and VR4. VR3 and VR4 in series provide a regulated 24V supply for the 26B power amplifier. If only +12, -12, and common are available as the external power source, they are fed in as follows:

- a. +12, pin 11
- b. -12, pin 10
- c. Common, pins 20, 21

The 26B will still develop +3.6V for external use in this mode.

NOTE

See strapping table for different modes.

23.02 Level Sensing (Detector)

1. This circuit consists of three sections:
 - a. Input high gain amplifier, LA1.
 - b. Detector and long-time constant filter.
 - c. Relay driver and reference setting.

2. Tone is fed into the 26B at pin 1 (Hi) and pin 13 (Lo).

The input control (R9) determines the signal level fed to the high gain amplifier LA1. This amplifier has a closed loop gain of approximately 148 and feeds the detector and time constant circuit.

3. The detector and filter circuit consists of CR5, C9, R15, C10 and R17. The diode CR5 rectifies the signal from the amplifier in the negative direction and feeds this voltage to the filter section. C9 acts as an input filter raising the -dc voltage to be fed through R15 to C10 and R17. It is much smaller than C10 and therefore has little effect on the timing. C10 charges via R15 and discharges through R17. Since R15 is larger than R17, C10 **takes** longer to charge than it does to discharge.

4. The reference setting on the relay driver' circuit determines the level that the detected dc must reach to cause the relay driver circuit (LA2) to switch state and operate relay K1. It must be remembered that when setting the input for a particular level of circuit activation,'the higher this setting is above operating level, the longer time it **takes** to activate the circuit; (i.e., it will take longer for the detector to build up sufficient dc if alarm is desired 6 dB above operating level than if alarm is desired at 1 dB above operating level).

5. Form "C" relay contacts are provided for external use to activate whatever alarm or indicator circuit is desired to be used externally. If the input control is set for an alarm or activating level of 2 dB below normal operating level, then it will take approximately 0.1 seconds for the circuit to deactivate depending on how rapidly the level is raised.

23.03 Power Amplifier

Voltage amplification is achieved by the use of an integrated circuit operational amplifier, LA3. The gain is approximately 100. Q5, Q6, Q3, Q4 form a power output stage. Q5 and Q6 are emitter follower phase inverters and Q3 and Q4 are complementary transistors used in a push-pull type circuit operating in the class **AB** mode.

(Located in back of manual.)

24.0 MAINTENANCE

24.01 General

Refer to system instruction manual Amplifier-Oscillator Group Model 2571D and Model 2571E paragraph 6.0 for maintenance pertaining to Model 26B Power Amplifier Module.

(Located in back of manual.)

CHAPTER 5

25.0 PURPOSE AND BASIC PRINCIPLES OF EXTENDER BOARD MODEL MC 10064-08

25.01 Application

The Extender Board Model MC10064-08, hereinafter referred to as extender is used in maintenance procedures. Proper use of the extender permits adjusting and testing of any module included in the signaling tone supply Model 2571D/E. .

25.02 Unit Description

1. The extender is a printed circuit board which does not contain components. It provides point- to-point connections from its rear connector to its front connector permitting work to be done on a module outside the shelf while being electrically connected to the shelf.

2. The board's locking device is released by pulling out the lever, thus permitting withdrawal of the extender from the shelf.

26.0 SPECIFICATIONS OF EXTENDER BOARD MODEL MC 10064-08

26.01 Electrical

1. One, 44 pin male connector (rear of extender)
2. One, 44 pin female connector (front of extender)
3. 44 Connecting printed circuits

26.02 Physical

Length: 11-1/2 inches
Height: 4-11/16 inches

26.03 Mechanical

Locking lever to secure card in shelf.

27.0 INSTALLATION OF EXTENDER BOARD MODEL MC 10064-08

27.01 General

Install the extender in the shelf by inserting it in the prepared slides until it is flush with the shelf edge; then depress the locking lever.

28.0 OPERATING INSTRUCTIONS FOR EXTENDER BOARD MODEL
MC 10064-08

28.01 General

1. Remove power from equipment.
2. Withdraw the extender and the printed circuit board to be tested or adjusted.
3. Insert the extender in the slot that contained the board to be tested, and insert the board male connector into the female extender connector-
4. Restore power to equipment.

NOTE

The board to be tested/adjusted is now in an extended position with all components exposed. The board is illustrated in figure 11.

(Located in back of **manual.**)

APPENDIX A
REFERENCES

AR 700-58	Report of Packaging and Handling Deficiencies	DA Pam 310-7	U. S. Army Index of Modification Work Orders
DA Pam 310-4	Index of Technical Publications: Technical Manuals, Technical Bulletins, Supply Manuals (Types 7, 8, and 9), Supply Bulletins, and Lubrication Orders	TM 38-750 TM 750-244-2	The Army Maintenance Management System (TAMMS) Procedures for Destruction of Electronics Materiel to Prevent Enemy Use (Electronics Command)

APPENDIX B MAINTENANCE ALLOCATION

Section I. INTRODUCTION

B-1. General

This appendix provides a summary of the maintenance operations for Amplifier-Oscillator, Telephone TA-909(V)1/GTC and Amplifier-Oscillator TA909(V)2/GTC. It authorizes categories of maintenance for specific maintenance functions on repairable items and components and the tools and equipment required to perform each function. This appendix may be used as an aid in planning maintenance operations.

B-2. Maintenance Function

Maintenance functions will be limited to and defined as follows:

a. Inspect. To determine the serviceability of an item by comparing its physical, mechanical, and/or electrical characteristics with established standards through examination.

b. Test. To verify serviceability and to detect incipient failure by measuring the mechanical or electrical characteristics of an item and comparing those characteristics with prescribed standards.

c. Service. Operations required periodically to keep an item in proper operating condition, i.e., to clean (decontaminate), to preserve, to drain, to paint, or to replenish fuel, lubricants, hydraulic fluids, or compressed air supplies.

d. Adjust. To maintain, within prescribed limits, by bringing into proper or exact position, or by setting the operating characteristics to the specified parameters.

e. Align. To adjust specified variable elements of an item to bring about optimum or desired performance.

f. Calibrate. To determine and cause corrections to be made or to be adjusted on instruments or test measuring and diagnostic equipments used in precision measurement. Consists of comparisons of two instruments, one of which is a certified standard of known accuracy, to detect and adjust any discrepancy in the accuracy of the instrument being compared.

g. Install. The act of emplacing, seating, or fixing into position an item, part, module (component or assembly) in a manner to allow the proper functioning of the equipment or system.

h. Replace. The act of substituting a serviceable like type part, subassembly, or module (component

or assembly) for an unserviceable counterpart.

i. Repair. The application of maintenance services (inspect, test, service, adjust, align, calibrate, replace) or other maintenance actions (welding, grinding, riveting, straightening, facing, re-machining, or resurfacing) to restore serviceability to an item by correcting specific damage, fault, malfunction, or failure in a part, subassembly, module (component or assembly), end item, or system.

j. Overhaul. That maintenance effort (service/action) necessary to restore an item to a completely serviceable/operational condition as prescribed by maintenance standards (i.e., DMWR) in appropriate technical publications. Overhaul is normally the highest degree of maintenance performed by the Army. Overhaul does not normally return an item to like new condition.

k. Rebuild. Consists of those services actions necessary for the restoration of unserviceable equipment to a like new condition in accordance with original manufacturing standards. Rebuild is the highest degree of materiel maintenance applied to Army equipment. The rebuild operation includes the art of returning to zero those age measurements (hours, miles, etc.) considered in classifying Army equipments/components.

B-3. Column Entries.

a. Column 1, Group Number. Column 1 lists group numbers, the purpose of which is to identify components, assemblies, subassemblies, and modules with the next higher assembly.

b. Column 2, Component/Assembly. Column 2 contains the noun names of components, assemblies, subassemblies, and modules for which maintenance is authorized.

c. Column 3, Maintenance Functions. Column 3 lists the functions to be performed on the item listed in column 2. When items are listed without maintenance functions, it is solely for purpose of having the group number in the MAC and RPSTL coincide.

d. Column 4, Maintenance Category. Column 4 specifies, by the listing of a "work-time" figure in the appropriate subcolumn (the lowest level of maintenance authorized to perform the function listed in column 3. This figure represents the active

time required to perform that maintenance function at the indicated category of maintenance. If the number or complexity of the tasks within the listed maintenance function vary at different maintenance categories, appropriate "work-time" figures will be shown for each category. The number of task-hours specified by the "work-time" figure represents the average time required to restore an item (assembly, subassembly, component, module, end item or system) to a serviceable condition under typical field operating conditions. This time includes preparation time, troubleshooting time, and quality assurance/quality control time in addition to the time required to perform the specific tasks identified for the maintenance functions authorized in the maintenance allocation chart. Subcolumns of column 4 are as follows:

- C - Operator/Crew
- O - Organizational
- F - Direct Support
- H - General Support
- D - Depot

e. Column 5, Tools and Equipment. Column 5 specifies by code, those common tool sets (not individual tools) and special tools, tests, and support equipment required to perform the designated function.

f. Column 6, Remarks. Column 6 contains an alphabetic code which leads to the remark in section IV, Remarks, which is pertinent to the item

opposite the particular code.

B-4. Tool and Test Equipment Requirements (Sect III)

a. Tool or Test Equipment Reference Code. The numbers in this column coincide with the numbers used in the tools and equipment column of the MAC. The numbers indicate the applicable tool or test equipment for the maintenance functions.

b. Maintenance Category. The codes in this column indicate the maintenance category allocated the tool or test equipment.

c. Nomenclature. This column lists the noun name and nomenclature of the tools and test equipment required to perform the maintenance functions.

d. National/NATO Stock Number. This column lists the National/NATO stock number of the specific tool or test equipment.

e. Tool Number. This column lists the manufacturer's part number of the tool followed by the Federal Supply Code for manufacturers (5-digit) in parentheses.

B-5. Remarks (Sect IV).

a. Reference Code. This code refers to the appropriate item in section II, column 6.

b. Remarks. This column provides the required explanatory information necessary to clarify items appearing in section II.

SECTION II MAINTENANCE ALLOCATION CHART

FOR

AMPLIFIER-OSCILLATOR, TELEPHONE TA-909(V)1/GTC AND AMPLIFIER-OSCILLATOR, TELEPHONE TA-909(V)2/GTC

(1) GROUP NUMBER	(2) COMPONENT/ASSEMBLY	(3) MAINTENANCE FUNCTION	(4) MAINTENANCE CATEGORY					(5) TOOLS AND EQPT.	(6) REMARKS
			C	O	F	H	D		
00	AMPLIFIER-OSCILLATOR, TELEPHONE TA-909(V)1/GTC AND TA-909(V)2/GTC	Inspect		0.2					
		Test			1.0			1-6	
		Repair		0.2				4	A
01	KEYER, 1600 Hz SINGER/TELESIGNAL 70794	Repair			2.0			1-6,13	
	KEYER, 2600 Hz SINGER/TELESIGNAL 70795	Test			1.3			1,2,3, 5-8,12	
02	AMPLIFIER, POWER SINGER/TELESIGNAL 26B	Adjust			0.8			1,2,5,6	
		Repair				2.0		1,2,3, 5-8,12, 13	
		Replace			0.3				
		Test			1.1			1,2,4, 5,6	
		Adjust			0.6			1,2,4, 5,6	
		Replace			0.3				
		Repair				2.2		1,2,4, 5,6,13	

SECTION III TOOL AND TEST EQUIPMENT REQUIREMENTS
FOR
 FIBER-OSCILLATOR, TELEPHONE TA-909(V)1/GTC AND AMPLIFIER-OSCILLATOR TA-909(V)2/GTC

TOOL OR TEST EQUIPMENT REF CODE	MAINTENANCE CATEGORY	NOMENCLATURE AVAILABLE ON SITE/ RECOMMENDED IN MANUAL MILITARY EQUIVALENT	NATIONAL/NATO STOCK NUMBER	TOOL NUMBER
1	F,H	POWER SUPPLY, EJE CORP. HT48-5*		
2	F,H	AC VOLTMETER, HP 400EL	AC VOLTMETER HP 400EL/HE-30/U	6625-00-669-9742
3	F,H	FREQUENCY METER, TSI 361	FREQUENCY COUNTER HP 5245L/ AN/USM-207A	6625-00-911-6368
4	O,F,H	VOM, SIMPSON 260	MULTIMETER SIMPSON 260/ TS-325B/U	6625-00-553-0142
5	F,H	FIXED FILM RESISTOR, MIL RM60C4991B		5905-00-960-2491
6	F,H	EXTENDER CARD, SINGER/TELE- SIGNAL MC10064-08		6625-00-437-4984
7	F,H	STORAGE OSCILLOSCOPE, HP 181A	OSCILLOSCOPE TEKTRONIX R561B WITH 3B3, 3A6, P6028, P6006	6625-00-442-3550
8	F,H	DC POWER SUPPLY, HP 6206B		6625-00-823-5359
9		DELETED		
10		DELETED		
11		DELETED		
12	F,H	PULSE/FUNCTION GENERATOR, EXACT ELEC. 126	SIGNALING TEST SET NEC TTS- 26BDR	5805-00-070-1063
13	F,H		TOOL KIT, ELECTRONIC TK-105/G	5180-00-610-8177
*NSN FOR THIS ITEM IS NOT AVAILABLE AT THIS TIME, BUT ACTION TO OBTAIN THIS NUMBER HAS BEEN TAKEN. THE NSN WILL BE PICKED UP IN THE NEXT PUBLISHED CHANGES TO THIS MANUAL				

SECTION IV. REMARKS

REFERENCE
CODE

REMARKS

A BY REPLACEMENT OF LAMPS, KNOBS, AND FUSES.

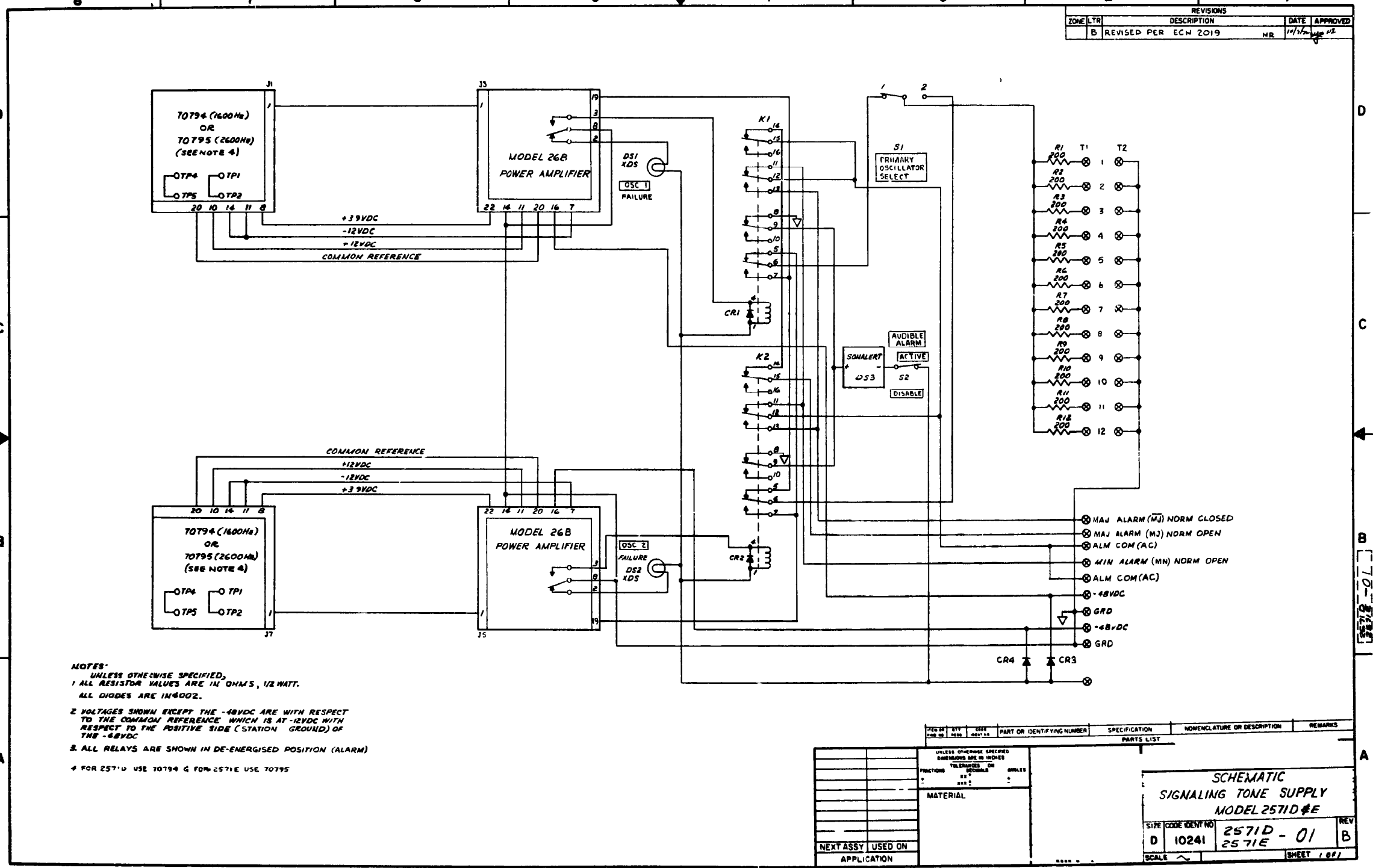

Figure 3 17

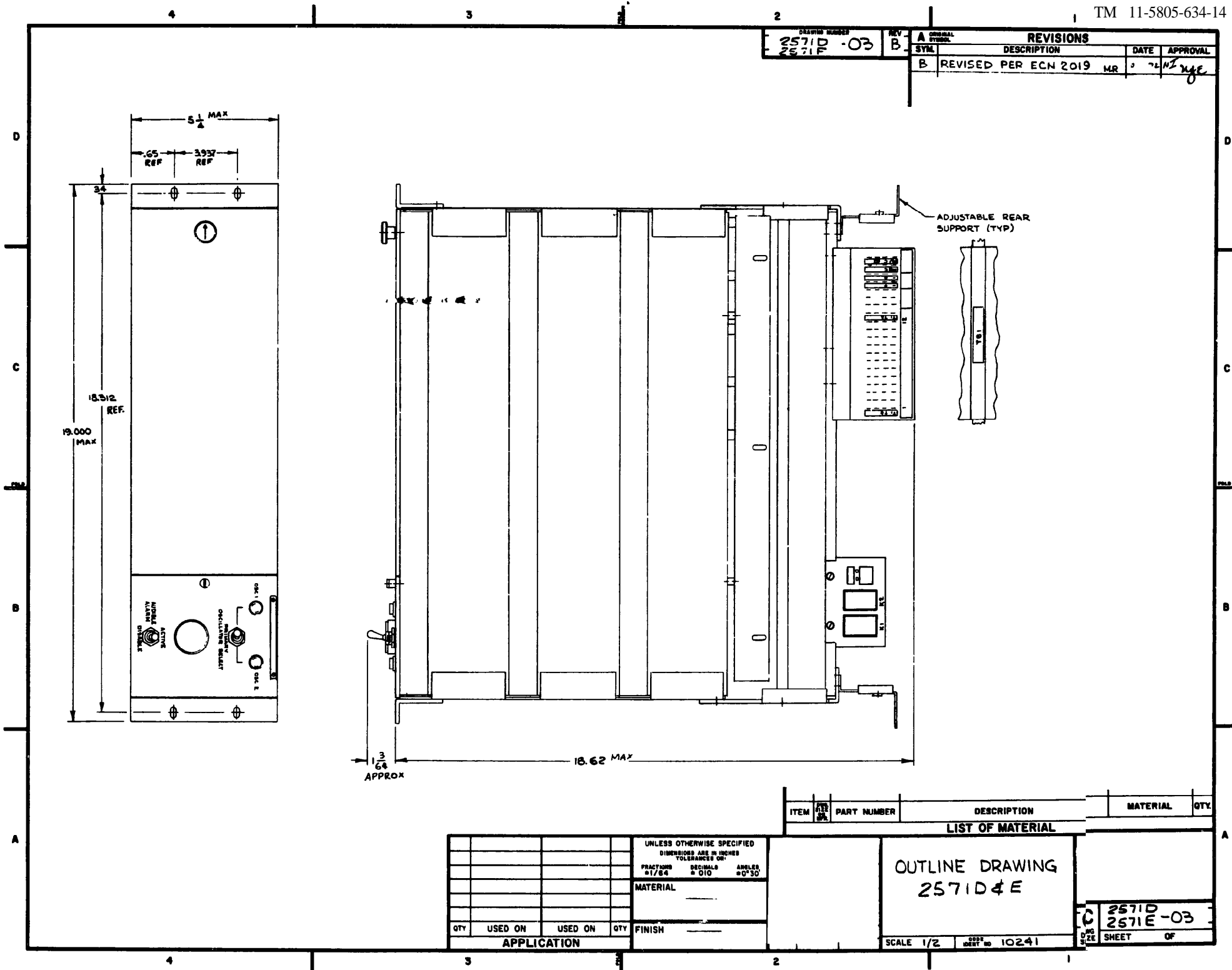
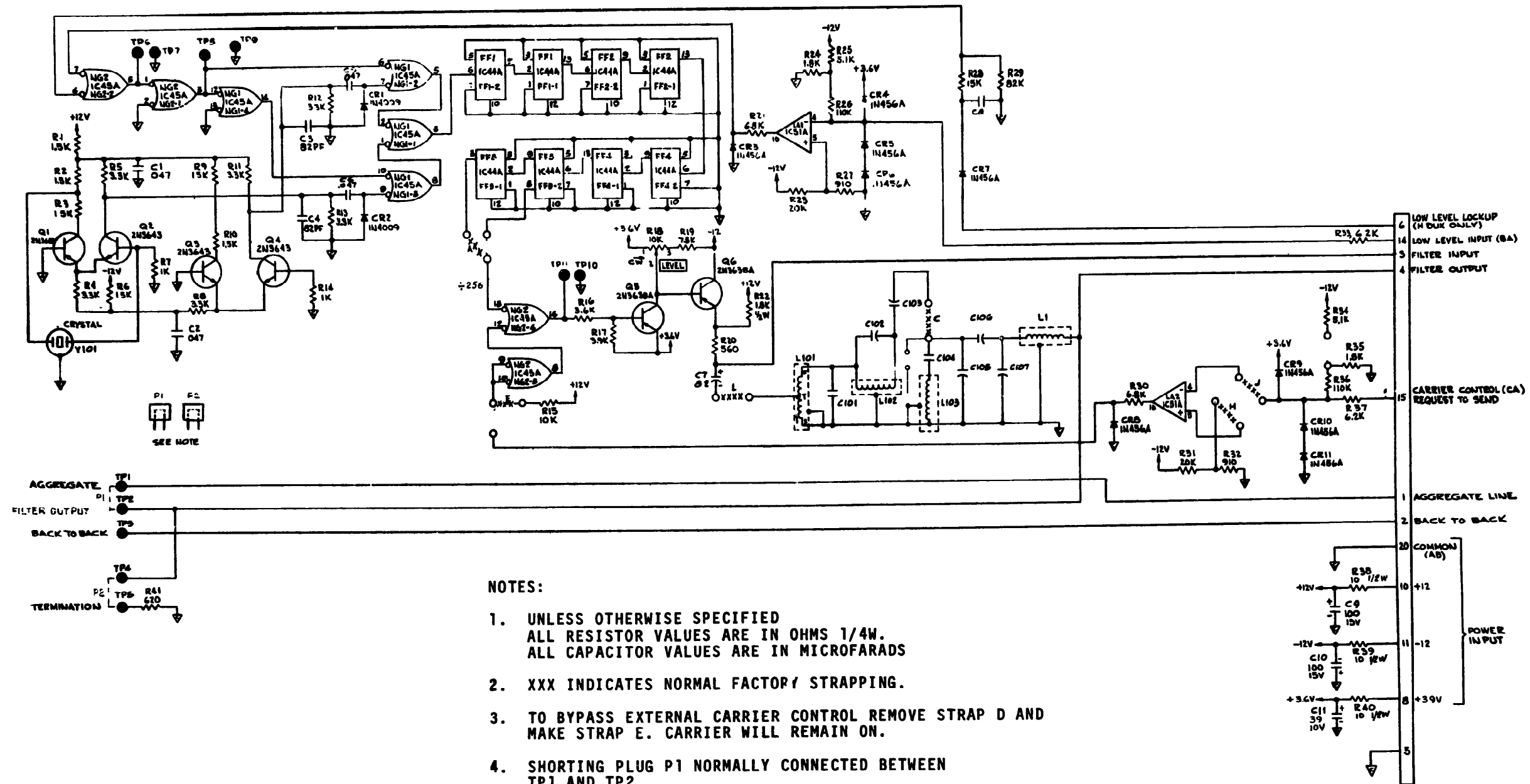

Figure 4 19



NOTES:

1. UNLESS OTHERWISE SPECIFIED ALL RESISTOR VALUES ARE IN OHMS 1/4W. ALL CAPACITOR VALUES ARE IN MICROFARADS.
2. XXX INDICATES NORMAL FACTORY STRAPPING.
3. TO BYPASS EXTERNAL CARRIER CONTROL REMOVE STRAP D AND MAKE STRAP E. CARRIER WILL REMAIN ON.
4. SHORTING PLUG P1 NORMALLY CONNECTED BETWEEN TP1 AND TP2. SHORTING PLUG P2 NORMALLY CONNECTED BETWEEN TP4 AND TP5.

Figure 5, Keyer 70794, Schematic

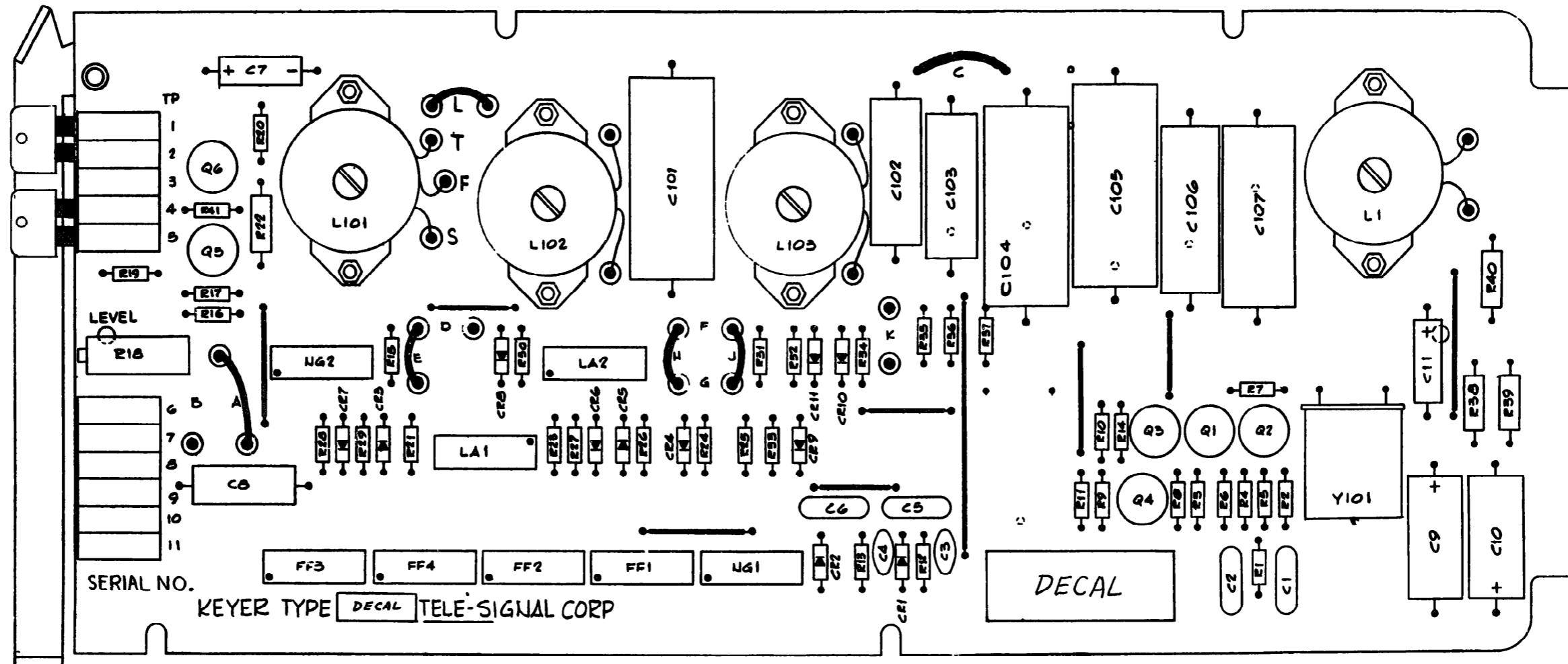

STRAPPING INSTRUCTIONS: MAKE THE FOLLOWING STRAPS A,C,E,L,H&J

Figure 6. Keyer 70794, Assembly

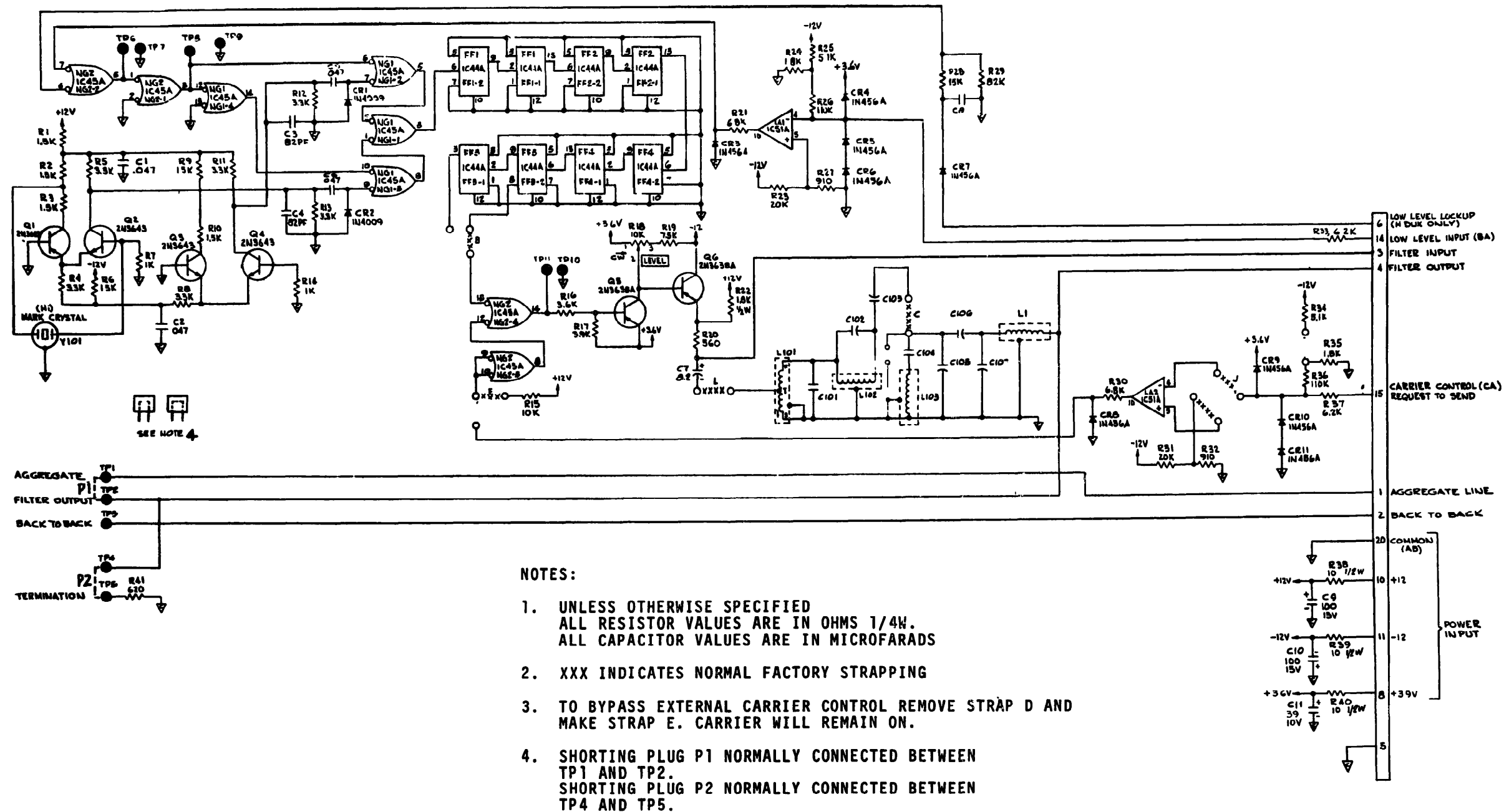
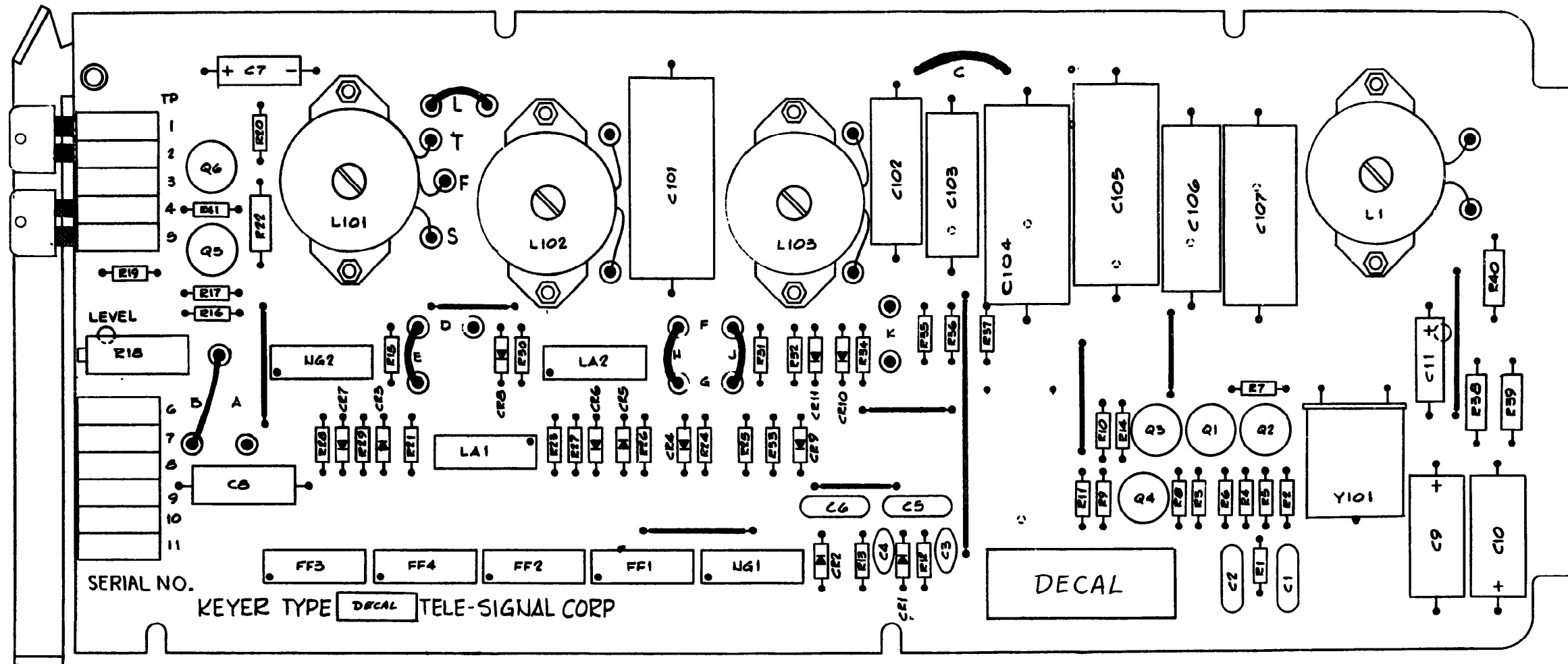

Figure 7. Keyer 70795, Schematic



STRAPPING INSTRUCTIONS : MAKE THE FOLLOWING STRAPS B,C,E,L,H & J

Figure 8. Keyer 70795, Assembly

REVISIONS		DATE	APPROVED
ZONE	LTR	DESCRIPTION	

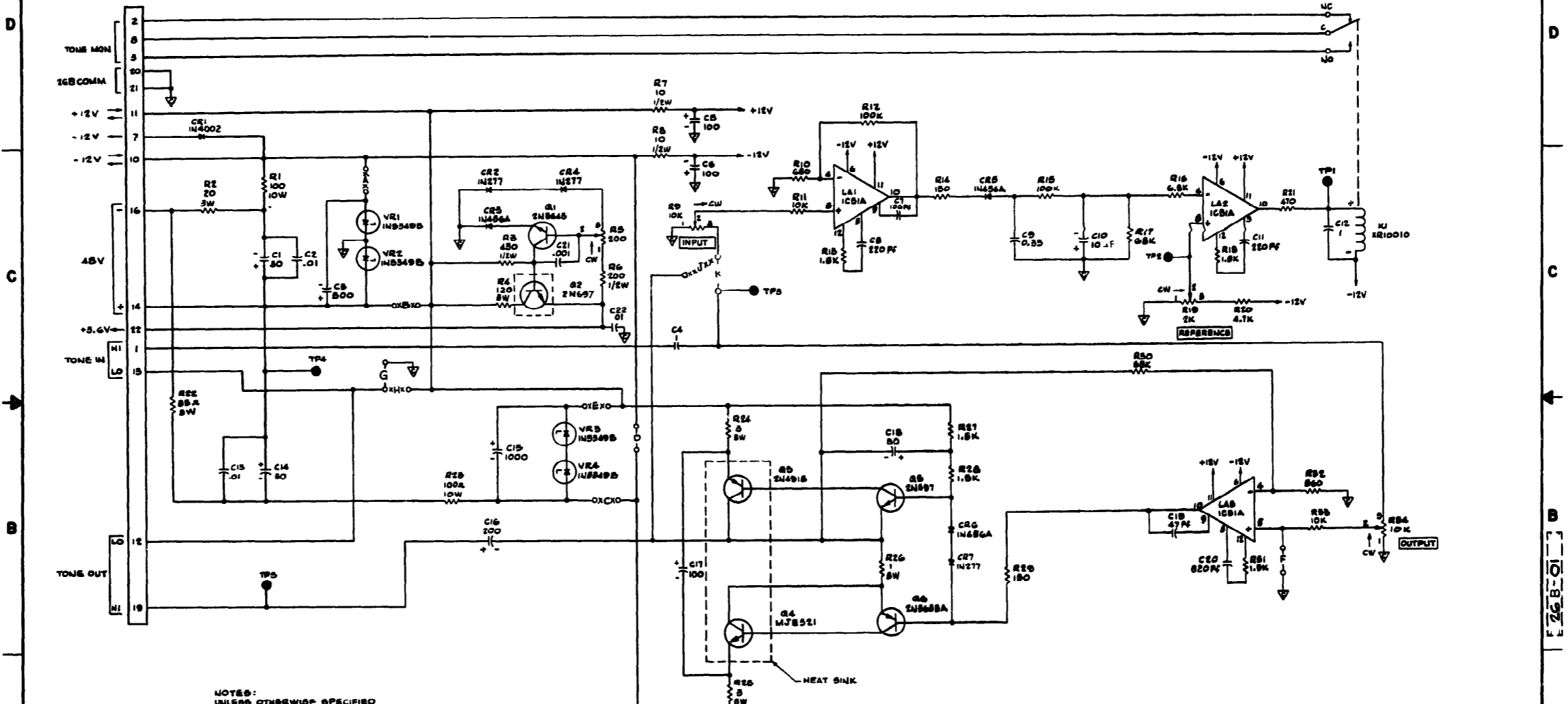

NOTES:
 UNLESS OTHERWISE SPECIFIED
 1 ALL RESISTOR VALUES ARE IN OHMS 1/4 WATT
 ALL CAPACITOR VALUES ARE IN MICROFARADS
 2 EXX INDICATES NORMAL FACTORY STRAPPING

QTY	REV	DATE	PART OR IDENTIFYING NUMBER	SPECIFICATION	NOMENCLATURE OR DESCRIPTION	REMARKS

UNLESS OTHERWISE SPECIFIED
 DIMENSIONS ARE IN INCHES
 TOLERANCE ON FRACTIONS:
 UNLESS:
 3 PLACE DECIMALS ±
 2 PLACE DECIMALS ±
 MATERIAL

SIZE	CODE	IDENT NO	DRAWING NO	REV
D	10241		26B-01	A

SCHEMATIC POWER AMPLIFIER MODEL 26B

NEXT ASSY USED ON APPLICATION

SCALE SHEET 1 OF 1

Figure 9 51

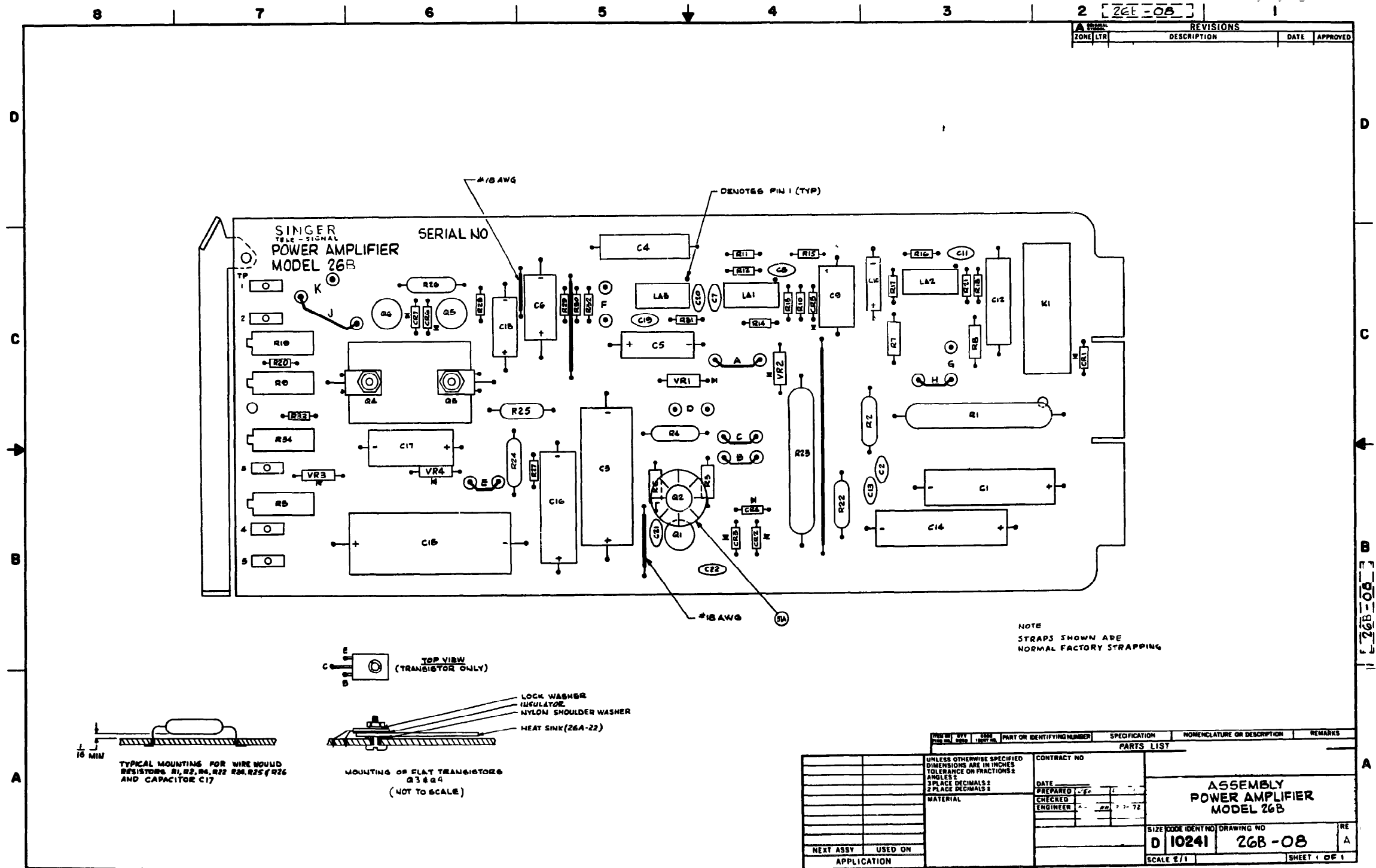

NOTE
STRAPS SHOWN ARE
NORMAL FACTORY STRAPPING

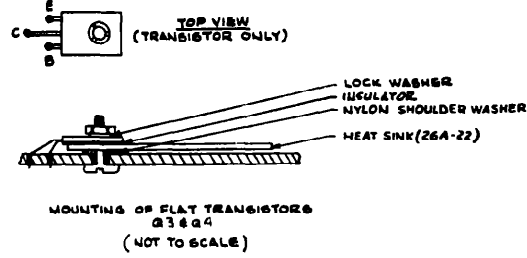
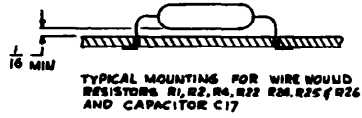

QTY	SYMBOL	DESCRIPTION	SPECIFICATION	NOMENCLATURE OR DESCRIPTION	REMARKS
PARTS LIST					
UNLESS OTHERWISE SPECIFIED DIMENSIONS ARE IN INCHES TOLERANCE ON FRACTIONS: NONE 3 PLACE DECIMALS: ± .005 2 PLACE DECIMALS: ± .010					
MATERIAL			CONTRACT NO.		
NEXT ASSY USED ON APPLICATION			DATE PREPARED: 7-72 CHECKED BY: [Signature] ENGINEER: [Signature]		
SIZE CODE IDENT NO		DRAWING NO		RE	
D 10241		26B-08		A	
SCALE 2/1				SHEET 1 OF 1	

Figure 10

DRAWING NUMBER
MC10064-08

REVISIONS			
SYMBOL	DESCRIPTION	DATE	APPROVAL
A	ORIGINAL SYMBOL		
B	EJECTOR ADDED	7-16-68	[Signature]
C	NOTE ADDED. PER ERN # 2300 PK	11/21/69	[Signature]
D	ADDED (4) SWAGE NUTS. ERN 2800 DWG	7-24-70	[Signature]

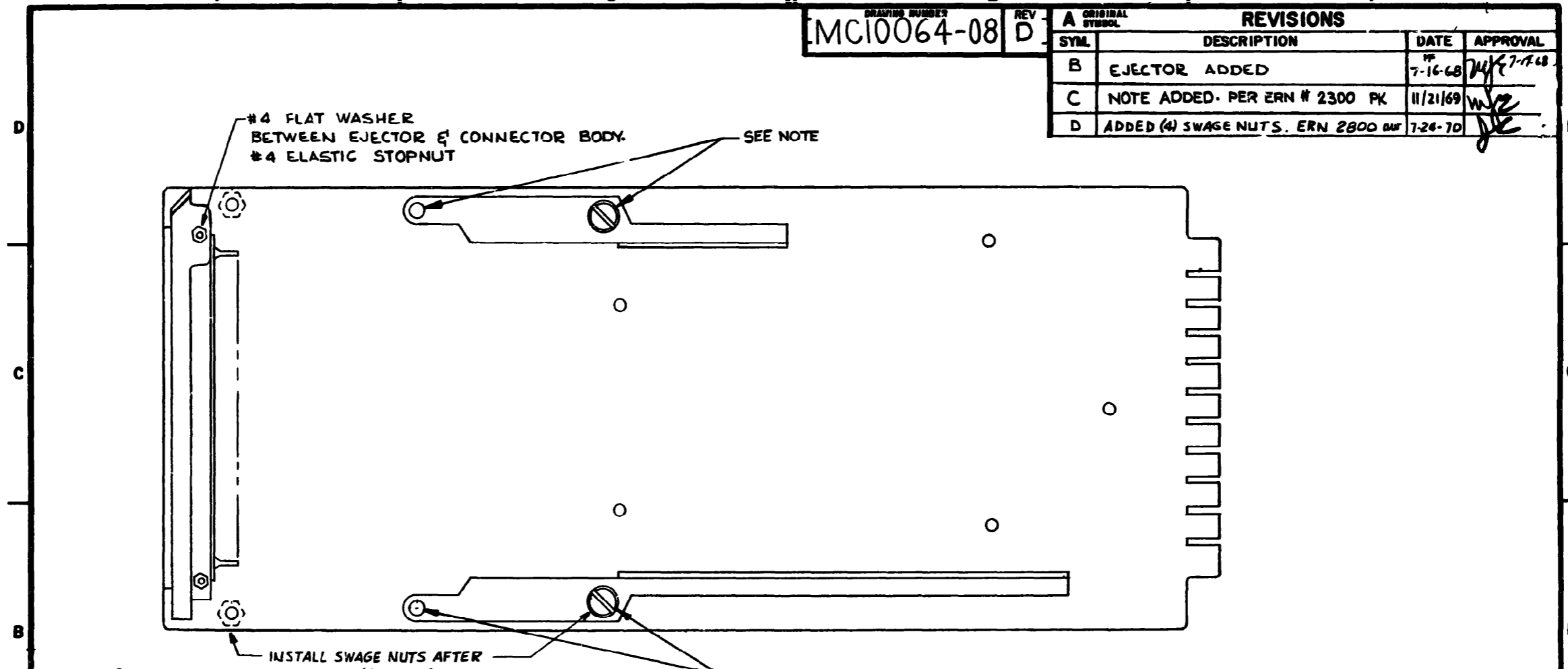

NOTE:
BEFORE RIVETING BRACKETS IN PLACE INSURE HOLE ALIGNMENT BY INSTALLING SCREW. USE 1/8 DIA BY 3/16 LONG HOLLOW ALUMINUM RIVETS (2 REQ'D.)

UNLESS OTHERWISE SPECIFIED DIMENSIONS ARE IN INCHES TOLERANCES ON:			
FRACTIONS	DECIMALS	ANGLES	
±1/64	±.005	±0°30'	
QTY	USED ON	USED ON	QTY
APPLICATION			
MATERIAL			
FINISH			

ITEM	DWG SIZE OR SPZ	PART NUMBER	DESCRIPTION	MATERIAL	QTY
LIST OF MATERIAL					
ASSEMBLY EXTENDER BOARD 44 PIN					
SCALE 1/1			CODE IDENT NO	B MC10064-08	
DWG SIZE			SHEET 1 OF 1		

By Order of the Secretary of the Army:

CREIGHTON W. ABRAMS
General, United States Army
Chief of Staff

Official:

VERNE L. BOWERS
Major General, United States Army
The Adjutant General

Distribution:

Active Army:

CNGB (1)
USASA (2)
ACSC-E (2)
USAMB (10)
AMC (1)
USACDCCEA (1)
USACDCCEA
 Ft Huachuca (1)
2d LOGCOMD (10)
ARADCOM (1)
OS Maj Comd (3)
USARPAC (3)
TECOM (2)
USASTRATCOM (5)
USASTRATCOM Sig Gp Okinawa (15)
USASTRATCOM Sig Gp-T (2)
USASTRATCOM Sig Gp Taiwan (10)
USASTRATCOM-Pac (3)
USAINTS (3)

USASESS (5)
HISA (ECOM) (18)
Army Depots (1) except
 SAAD (20)
 TOAD (14)
 LBAD (5)
 LEAD (5)
Gen Dep (Pac) (2)
Sig Sec Gen Dep (Pac) (2)
Sig Dep (Pac) (2)
MAAG, Republic of China (2)
USACSA (3)
Sig FLDMS (Pac) (1)
Units org under fol TOE:
 (1 cy each)
 11-158
 11-302
 29-134
 29-136

NG & USAR: None

For explanation of abbreviations used, see AR 310-50.

**DEPARTMENT OF THE ARMY
US ARMY AG PUBLICATIONS CENTER
1655 WOODSON ROAD
ST LOUIS MISSOURI 63114**

**OFFICIAL BUSINESS
PENALTY FOR PRIVATE USE \$300**

**POSTAGE AND FEES PAID
DEPARTMENT OF THE ARMY
DOD 314**



END

DATE

11-10-82





DEPARTMENT OF THE ARMY
MICROFORM
TEST TARGET

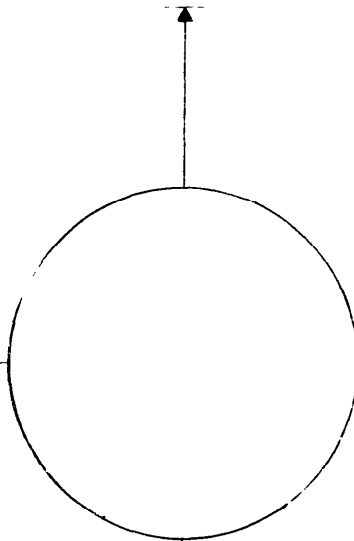
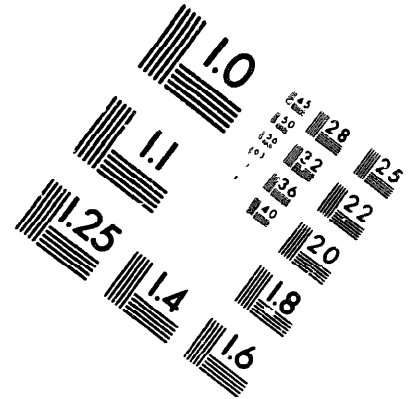
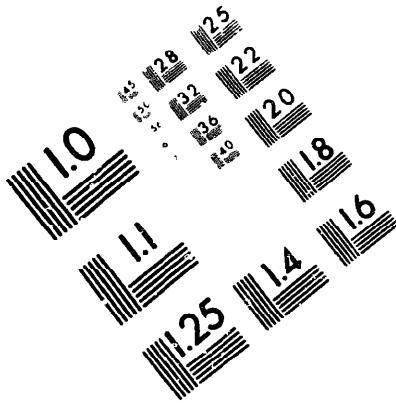

150 MM

1.0 mm (e = 81 mm)

ABCDEFGHIJKLMNQRSTUWVXYZ1234567890
abcdefghijklmnopqrstuvwxyz\$%# 1/2 1/4 3/4 — = + x & @ *

1.5 mm (e = 109 mm)

ABCDEFGHIJKLMNQRSTUWVXYZ1234567890
abcdefghijklmnopqrstuvwxyz\$%# 1/2 1/4 3/4 — = + x & @ *

2.0 mm (e = 137 mm)

ABCDEFGHIJKLMNQRSTUWVXYZ
abcdefghijklmnopqrstuvwxyz
1234567890\$%# 1/2 1/4 3/4 — = + x & @ *

2.5 mm (e = 177 mm)

ABCDEFGHIJKLMNQRSTUWVXYZ
abcdefghijklmnopqrstuvwxyz
1234567890\$%# 1/2 1/4 3/4 — = + x & @ *

1.0 mm (e = 81 mm)

ABCDEFGHIJKLMNQRSTUWVXYZ1234567890
abcdefghijklmnopqrstuvwxyz\$%# 1/2 1/4 3/4 — = + x & @ *

1.5 mm (e = 109 mm)

ABCDEFGHIJKLMNQRSTUWVXYZ1234567890
abcdefghijklmnopqrstuvwxyz\$%# 1/2 1/4 3/4 — = + x & @ *

2.0 mm (e = 137 mm)

ABCDEFGHIJKLMNQRSTUWVXYZ
abcdefghijklmnopqrstuvwxyz
1234567890\$%# 1/2 1/4 3/4 — = + x & @ *

2.5 mm (e = 177 mm)

ABCDEFGHIJKLMNQRSTUWVXYZ
abcdefghijklmnopqrstuvwxyz
1234567890\$%# 1/2 1/4 3/4 — = + x & @ *

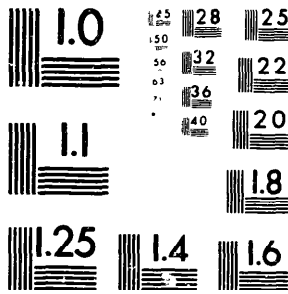

200 MM

250 MM

